

Motto:

*The science wouldn't be so good today,
if yesterday we hadn't thought about today.*

Grigore C. Moisil

ECCENTRICITY, SPACE BENDING, DIMENSION

Marian Nitu

*Dumbravita
Str. Kos Karoly Nr. 10, Cod Postal 307160
Judetul Timis
Romania
e-mail: nitumarian13@gmail.com*

Florentin Smarandache

*University of New Mexico
705 Gurley Ave. Gallup, NM 87301
USA
e-mail: smarand@unm.edu*

Selariu Mircea

*Str. Harnicieii
Nr.10, Ap.6, Cod Postal 300507
Timisoara
Romania
e-mail: mselariu@yahoo.com*

Abstract. The main goal of this paper is to present new transformations, previously non-existent in traditional mathematics, that we call centric mathematics (CM) but that became possible due to the new born eccentric mathematics, and, implicitly, to the supermathematics (SM).

As shown in this work, the new geometric transformations, namely conversion or transfiguration, wipe the boundaries between discrete and continuous geometric forms, showing that the first ones are also continuous, being just apparently discontinuous.

Abbreviations and annotations

C	▶	Circular and Centric,	E	▶	Eccentric and Eccentrics,
F	▶	Function,	M	▶	Mathematics,
CE	▶	Circular Eccentric,	F CE	▶	FCE,
CM	▶	Centric M,	EM	▶	Eccentric M,
SM	▶	Super M,	F CM	▶	FCM,
F EM	▶	FEM,	F SM	▶	FSM

Introduction: conversion or transfiguration

In *linguistics* a **word** is the fundamental unit to communicate a meaning. It can be composed by one or more *morphemes*. Usually, a word is composed by a basic part, named *root*, where one can attach *affixes*. To define some *concepts* and to express the domain where they are available, sometimes more words are needed: two, in our case. In this paper several new concepts are introduced and they are related to *SuperMathematics* (SM).

The principal new idea in this paper is that it introduces a new mathematical transformation with a large significance in the fields of Physics, previously non-existent in the original classical mathematics, named herein as centric mathematics (CM). They became possible thanks to this new mathematics called Eccentric Mathematics (EM) and to the Super Mathematics (SM), which are puts together with (CM) with (EM). The (CM) is now a particular case of a linear numeric eccentricity for $s = 1$ in (SM).

Supermathematical conversion

The concept is the easiest and methodical *idea* which reflects a finite of one or more series of attributes, where these attributes are *essentials*.

The concept is a minimal coherent and usable information, relative to an object, action, property or a defined event.

According to the Explicatory Dictionary, **the conversion** is, among many other definitions/meanings, defined as “changing the nature of an object”.

Next, we will talk about this thing, about transforming/changing/converting, previously impossible in the ordinary classic mathematics, now named also CENTRIC (CM), of some forms in others, and that became possible due to the new born mathematics, named ECCENTRIC (EM) and to the new built-in mathematical complements, named temporarily also SUPERMATHEMATICS (SM).

We talk about the *conversion* of a circle into a square, of a sphere into a cube, of a circle into a triangle, of a cone into a pyramid, of a cylinder into a prism, of a circular torus in section and shape into a square torus in section and/or form, etc. (Fig.1).

Supermathematical Conversion (SMC) is an internal pry for the mathematical dictionary enrichment, which consists in building-up of a new denomination, with one or more new terms (two in our case), by assimilating some words from the current language in a specialized domain, as Mathematics, with the intention to name and adequate the new operations that became possible only due to the new born *eccentric mathematics*, and implicitly to *supermathematics*. Because previously mentioned conversions could not be made until today in MC, but only in SM, we need to call them as SUPERMATHEMATICAL conversion (SMC).

In [14] the continuous transformation of a circle into a square was named also *eccentric transformation*, because, in that case, the linear numeric eccentricity s varies/grows from 0 to 1, being a slide from centric mathematics domain $MC \rightarrow s = 0$ to the eccentric mathematics, $ME(s \neq 0) \rightarrow s \in (0, 1]$, where the circular form draws away more and more from the circular form until reaching a perfect square ($s = \pm 1$).

Eccentric transformation

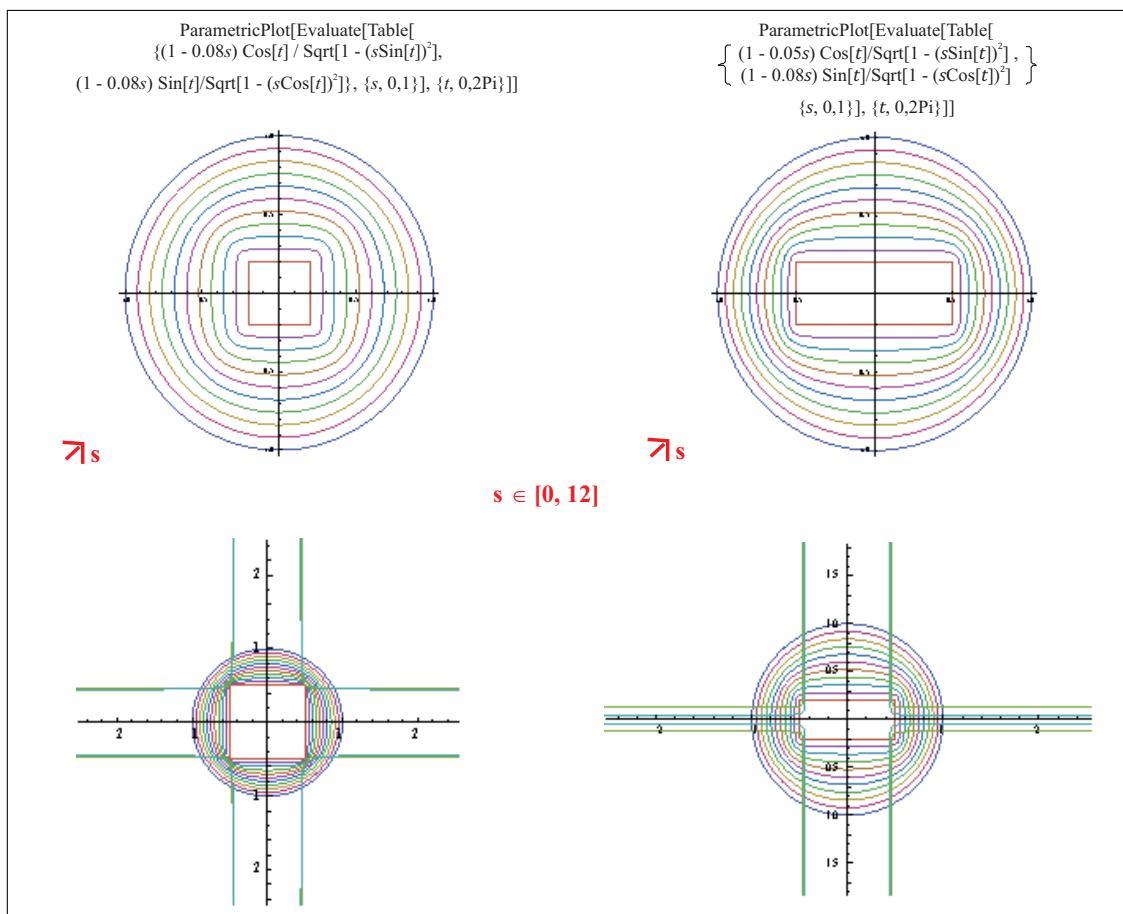

Figure 1: Conversion or transfiguration in 2D of a circle into a square and/or into a rectangle ►ECCENTRIC TRANSFORMATION

In the same work, the reverse transformation, of a square into a circle, was named as *centering transformation*. Same remarks are valid also for transforming a circle into a rectangle and a rectangle into a circle (Fig. 2). Most modern physicists and mathematicians consider that the numbers represent the reality's language. The truth is that the forms are those which generate all physical laws.

Centering transformation

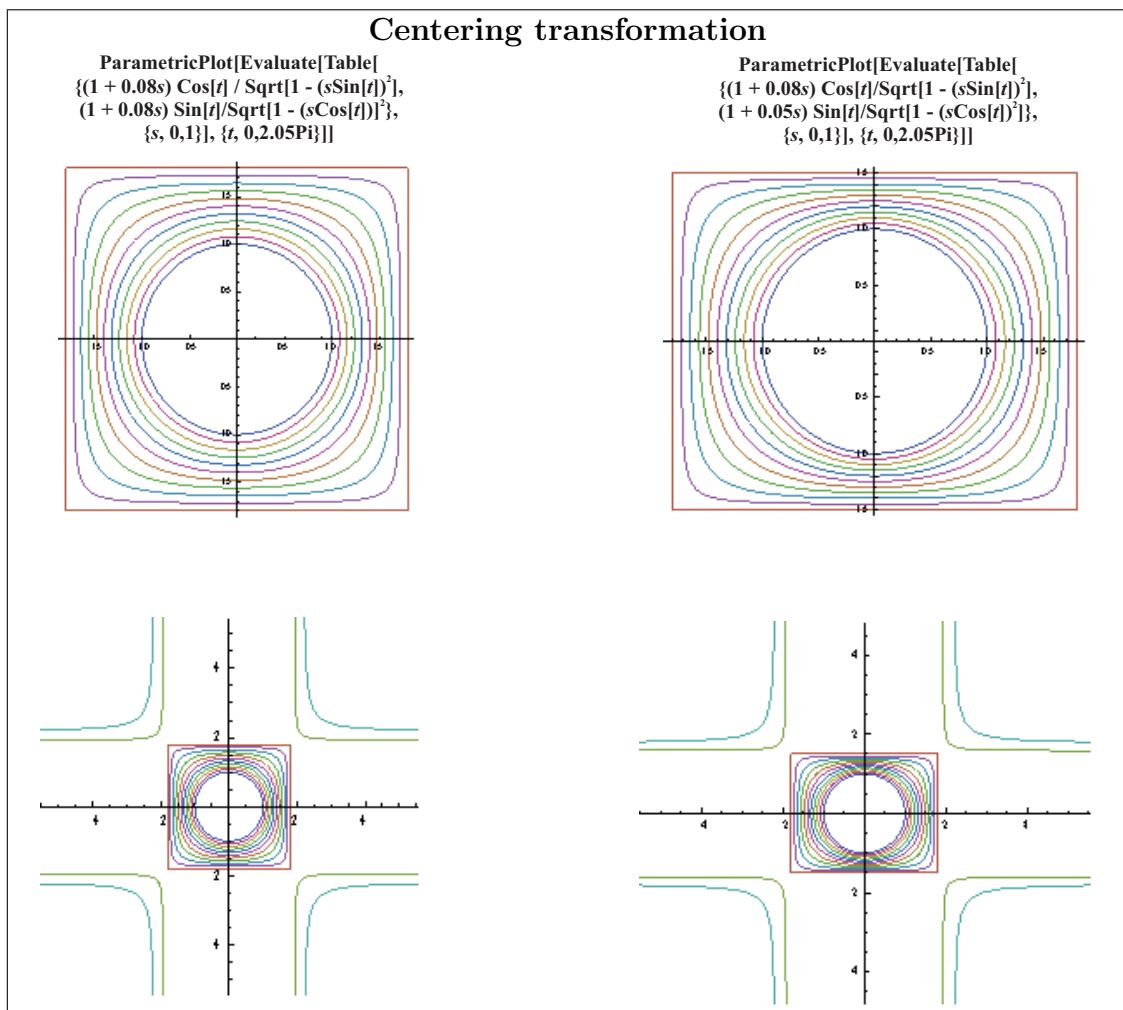

Figure 2: Conversion or transfiguration in 2D of a square and/or a rectangle into a circle ► CENTERING TRANSFORMATION

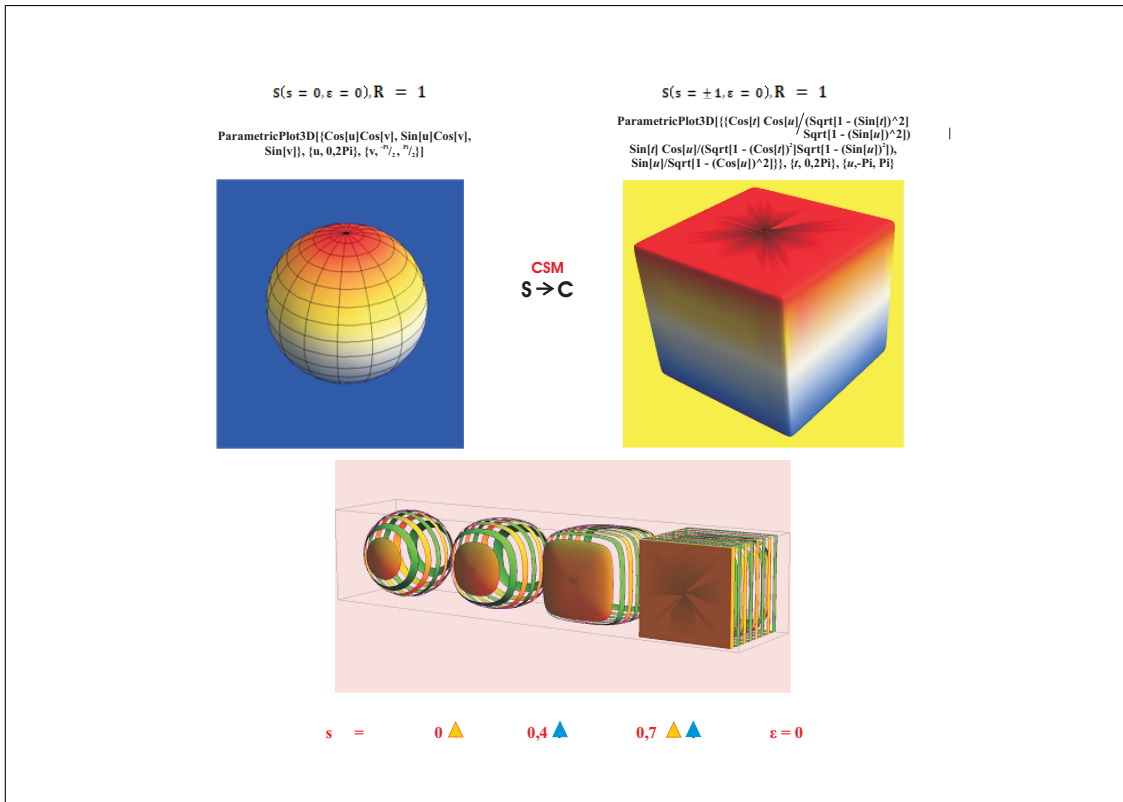

Figure 3: The conversion of a sphere into a cube

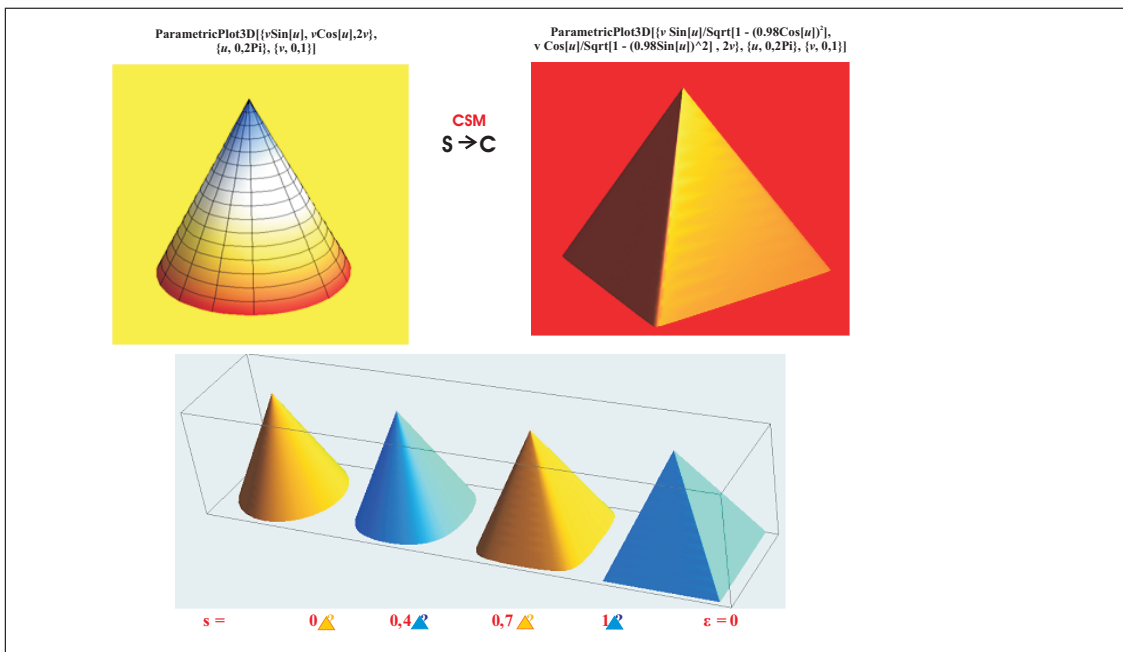

Figure 4: The Conversion of a cone into a pyramid

Look what the famous Romanian physicist Prof. Dr. Liviu Sofonea in *Representative Geometries and Physical Theories*, Ed. Dacia, Cluj-Napoca, p. 24, in 1984, in the chapter named *Mathematical geometry and physical geometry* wrote: In the *centric mathematical geometry* one does what can be done, how can be done, with what can be done, and in supermathematical geometry we can do what must be done, with what must be done, as we will proceed. In the *supermathematical geometry*, between the elements of the 'CM scaffold', one can introduce as many other constructive elements as we want, which will give an infinitely denser scaffold structure, much more durable and, consequently, higher, able to offer an unseen high level and an extremely deep description and gravity.

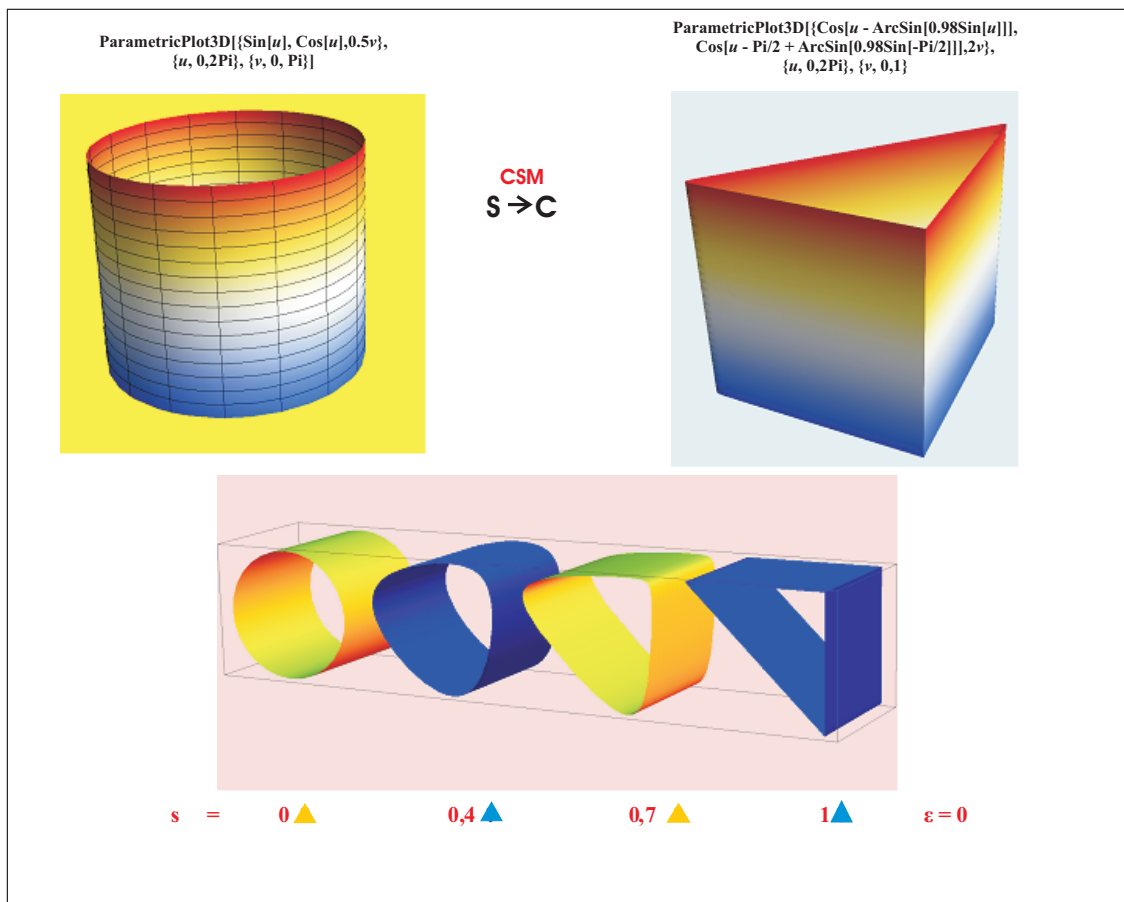

Figure 5: The Conversion or transfiguration of a cylinder into a prism

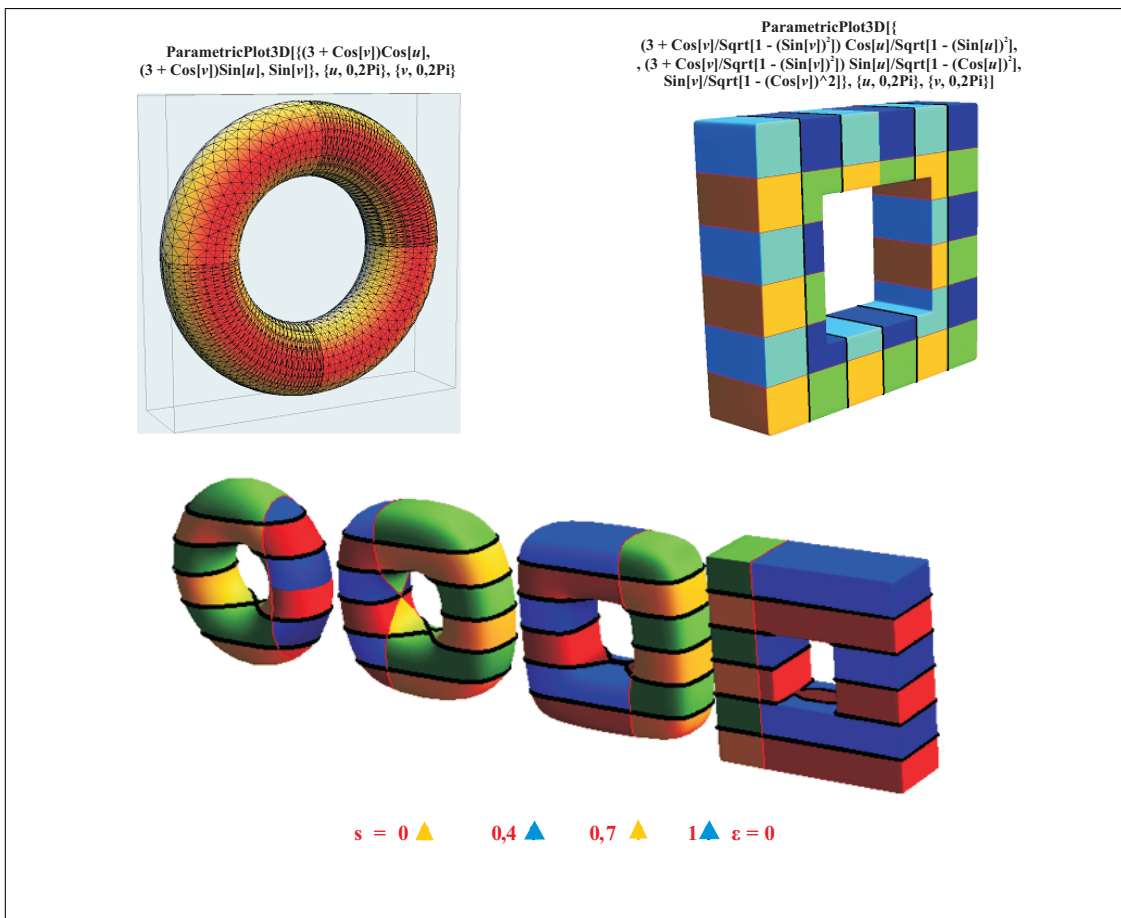

Figure 6: The conversion or transfiguration of the circular torus into a square torus, both in form and in section

The *fundamental principles* of the geometry are, according to their topological dimensions: the *corps* (3), the *line* (2), and the *point* (0).

The *elementary principles* of geometry are the point, the line, the space, the curve, the plane, the geometrical figures (such as the segment, triangle, square, rectangle, rhombus, the polygons, the polyhedrons, etc. the arcs, circle, ellipse, hyperbola, the scroll, the helix, etc.) both in 2D and in 3D spaces.

With the fundamental geometrical elements are defined and built all the forms and geometrical structures of the objects:

- *Discrete (discontinuous) statically forms*, or directly starting from a finite (discrete) set of points statically bonded with lines and planes.
- *Continuous (or dynamical, mechanical) forms*, starting from a single point and considering its motion, therefore the time, and obtaining in this way continuous forms of curves, as trajectories of points or curves, in the plane (2D) or in the space (3D)

Consequently, one has considered, and still is considering, the existence of two geometries: the *geometry of discontinuous*, or discrete geometry, and the *geometry of the continuum*.

As both objects limited by plane surfaces (cube, pyramid, prism), *apparently discontinuous*, as those limited by different kinds of *continuous surfaces* (sphere, cone, cylinder) can be described with the same parametric equations, the first ones for numerical eccentricity $s = \pm 1$ and the last ones for $s = 0$, it results that in SM there exists only one geometry, *the geometry of the continuum*.

In other words, the SM erases the boundaries between continuous and discontinuous, as SM erased the boundaries between linear and nonlinear, between centric and eccentric, between ideal/perfection and real, between circular and hyperbolic, between circular and elliptic, etc.

Between the values of numerical eccentricity of $s = 0$ and $s = \pm 1$, there exist an infinity of values, and for each value, an infinity of geometrical objects, which, each of them has the right to a geometrical existence.

If the geometrical mathematical objects for $s \in [0 \vee \pm 1]$ belong to the centric ordinary mathematics (CM) (circle \rightarrow square, sphere \rightarrow cube, cylinder \rightarrow prism, etc.), those for $s \in (0, \pm 1)$ have forms, equations and denominations unknown in this centric mathematics (CM). They belong to the new mathematics, the eccentric mathematics (EM) and, implicitly, to the supermathematics (SM), which is a reunion of the two mathematics: centric and eccentric, that means $SM = MC \cup ME$.

Concluding remarks

The principal new idea in this paper is that it introduces a new mathematical transformation with a large significance in the fields of Physics, previously inexistent in the original classical mathematics named here as centric mathematics (CM); and now they became possible thanks to this new mathematics, called Eccentric Mathematics (EM), and to the Super Mathematics (SM), which are put together: (CM) with (EM). The (CM) is now a particular case of a linear numeric eccentricity for $s = 1$ in (SM).

In this paper the authors prove that these new geometric transformations, named Conversions or Transfigures, eliminate the borders between the discrete and continuous forms, showing that the first ones are also continuous but only apparently continuous. They mean: the conversion of a circle in a square, of a sphere in a cube, of a circle in a triangle, of a cone in a pyramid, of a cylinder in a prism, of a torus with circular section in a torus with a square section, etc. Also, they consider this eccentricity in the formation and deformation of the space. The authors claim that all of these transformations are possible because of the eccentricity considered as 4-th up to n-th dimension of the space to complete the usual accepted (x, y, z) dimension. This is the reason why they consider the eccentricity as a dimension of the formation or deformation of the space.

The extension of a three dimensional space to a n-dimensional space became possible if the linear constant eccentricity e and the angle eccentricity ϵ which are the polar coordinates of the eccentricity E (e , ϵ) became of one or multiple variables considered eccentricities too.

References

- [1] SMARANDACHE, FL., SELARIU, M.E., *Immediate calculation of some poisson type integrals using supermathematics circular EccENTRIC functions*, arXiv: 0706.4238v1 [math.GM]
- [2] SELARIU, M.E., *Functii circulare excentrice*, Com. I Conferinta Nationala de Vibratii în Constructia de Masini, Timisoara, 1978, 101–108.
- [3] SELARIU, M.E., *Functii circulare excentrice si extensia lor*, Bul. St. Tehn. I.P. "TV" Timisoara, Seria Mecanica, Tom 25 (39), Fasc. 1 (1980), 189–196.
- [4] SELARIU, M.E., *The definition of the elliptic eccentric with fixed eccentric*, A V-a Conf. Nat. Vibr. Constr. Masini, Timisoara, 1985, 175–182.
- [5] SELARIU, M.E., *Elliptic eccentrics with mobile eccentric*, A V-a Conf. Nat. Vibr. Constr. Masini, Timisoara, 1985, 183–188.
- [6] SELARIU, M.E., *Circular eccentrics and hyperbolics eccentrics*, Com. a V-a Conf. Nat. V.C.M. Timisoara, 1985, 189-194.
- [7] SELARIU, M.E., *Eccentric Lissajous figures*, Ccom. a V-a Conf.Nat. V.C.M. Timisoara, 1985, 195-202.
- [8] SELARIU, M.E., *Supermatematica*, Com. VII Conf. Internat. Ing. Manag. Tehn., TEHNO'95 Timisoara, vol. 9 (1995), Matematica Aplicata, 41-64.
- [9] SELARIU, M.E., *Smarandache stepped functions*, Revista Scientia grande.
- [10] SELARIU, M.E., *Supermatematica. Fundamente*, Editura Politehnica, Timisoara, 2007.
- [11] SELARIU, M.E., *Supermatematica. Fundamente*, Vol. I. Editia a 2-a, Editura Politehnica, Timisoara, 2012.
- [12] SELARIU, M.E., *Supermatematica. Fundamente*, Vol. II. Editia a 2-a, Editura Politehnica, Timisoara, 2012.
- [13] SELARIU, M.E., SMARANDACHE, FL., NITU, M., *Cardinal functions and integral functions*, International Journal Of Geometry, vol. I, (2012), no. 1, 5-14.

- [14] SELARIU, M.E., *Spatiul matematicii centrice si spatiul matematicii excentrice*, www.cartiAZ.ro, the 6th page, 2012.
- [15] SELARIU, M.E., *Matematica atomica. Metoda determinarii succesive a cifrelor consecutive ale unui numar*, www.cartiAZ.ro, the 4th page, 2012.

Accepted: 30.03.2013